

RF Block diagram v.24

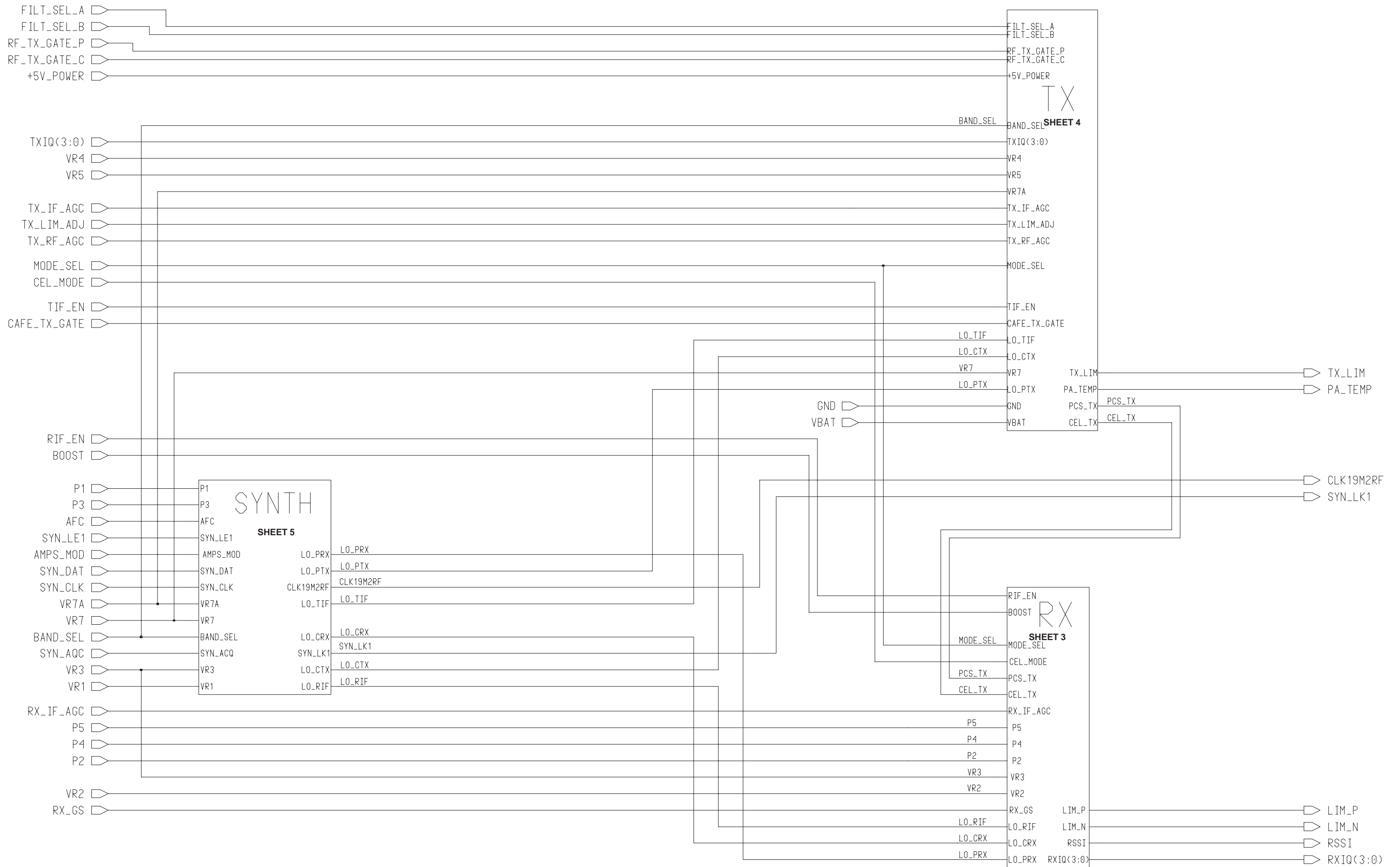

BB-RF interface (Version 06.0 Edition 8) for layout version 24

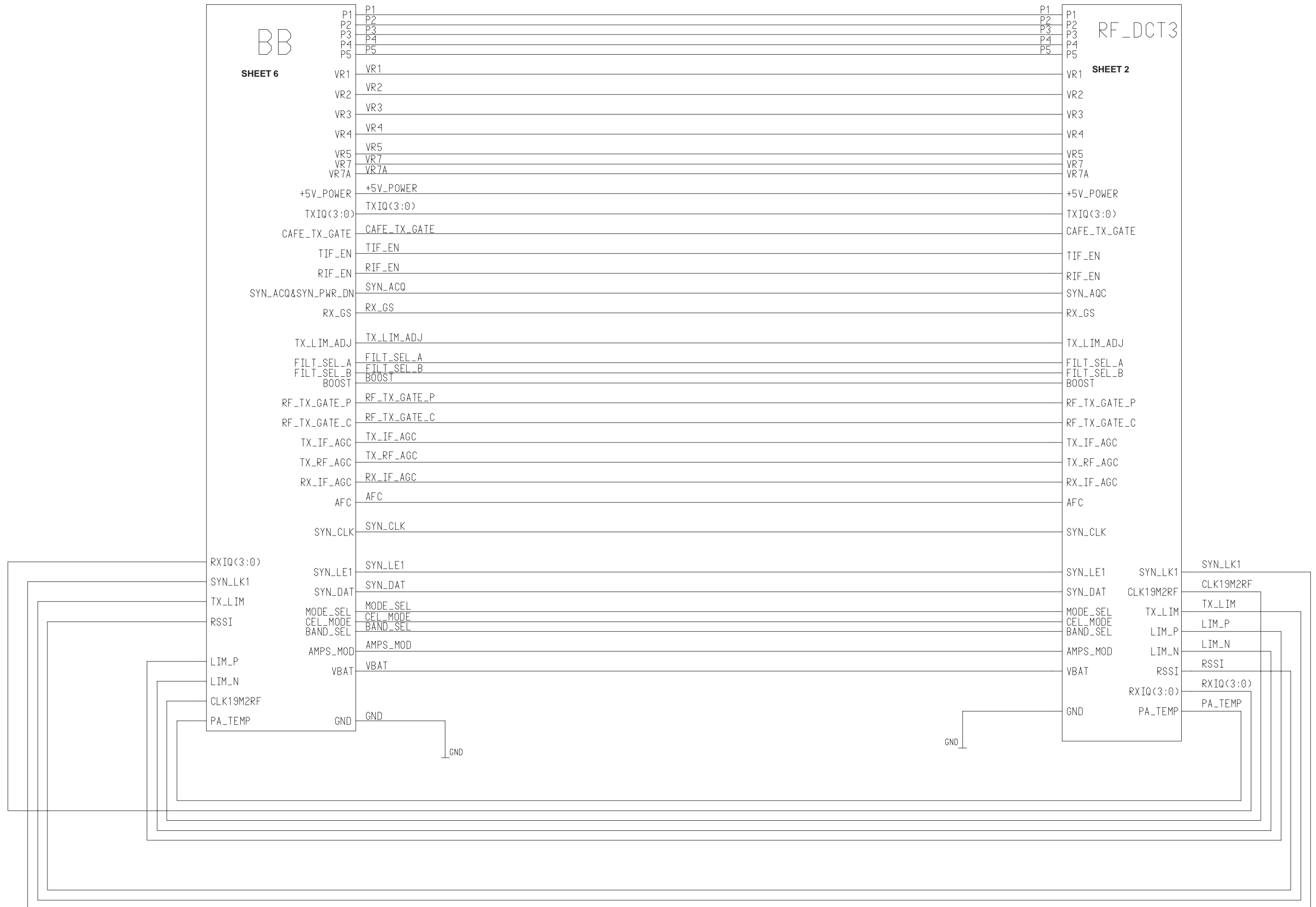

Block Diagram of BB (Version 06.0 Edition 9) for layout version 24

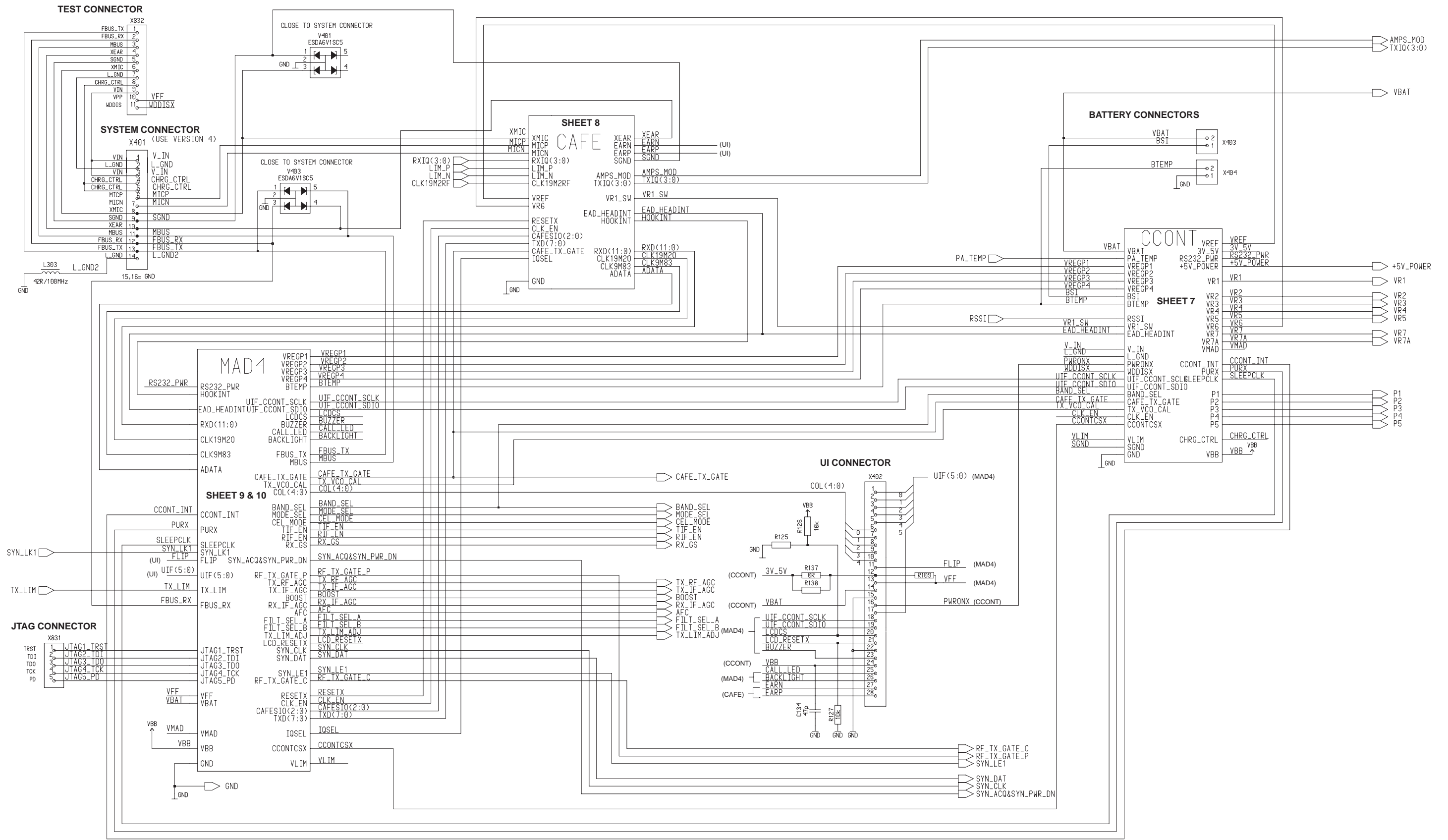

Circuit Diagram of Power Supply (Version 06.0 Edition 8) for layout version 24

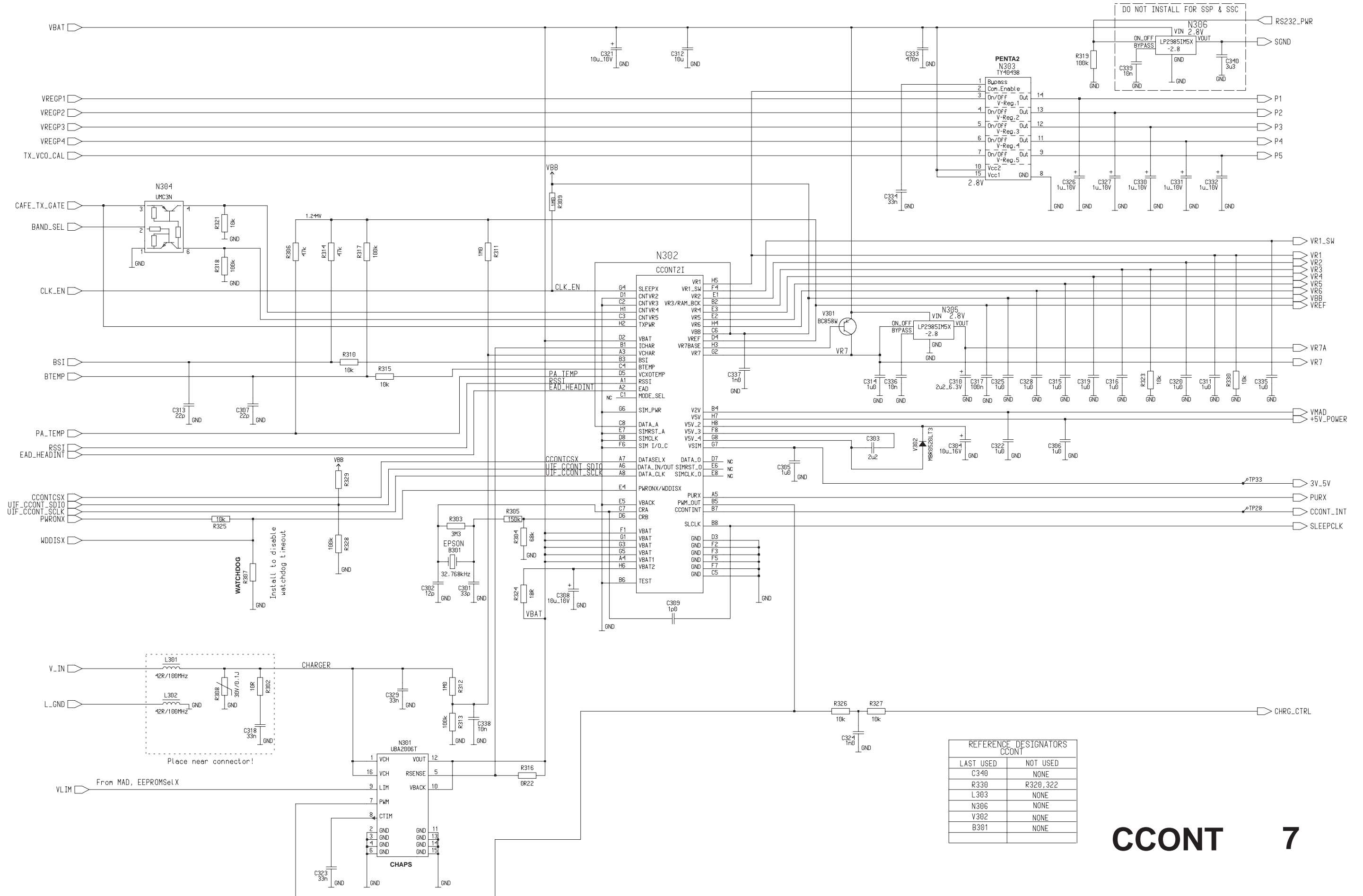

CCONT 7

Circuit Diagram of RX (Version 06.0 Edition 10) for layout version 24

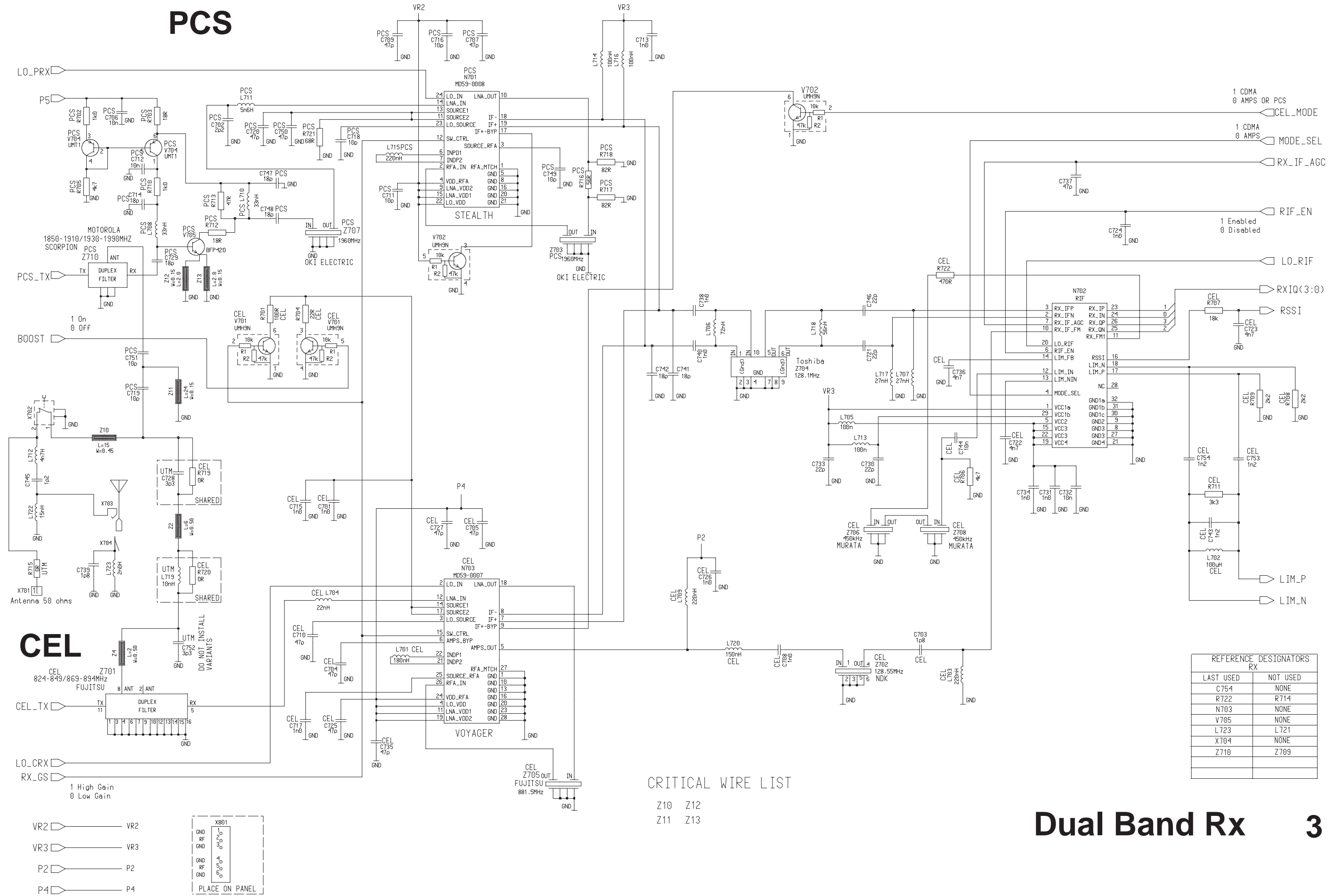

CRITICAL WIRE LIST

- Z10 Z12
- Z11 Z13

REFERENCE DESIGNATORS RX	
LAST USED	NOT USED
C754	NONE
R722	R714
N703	NONE
V705	NONE
L723	L721
X704	NONE
Z710	Z709

Dual Band Rx 3

Circuit Diagram of TX (Version 06.0 Edition 8) for layout version 24

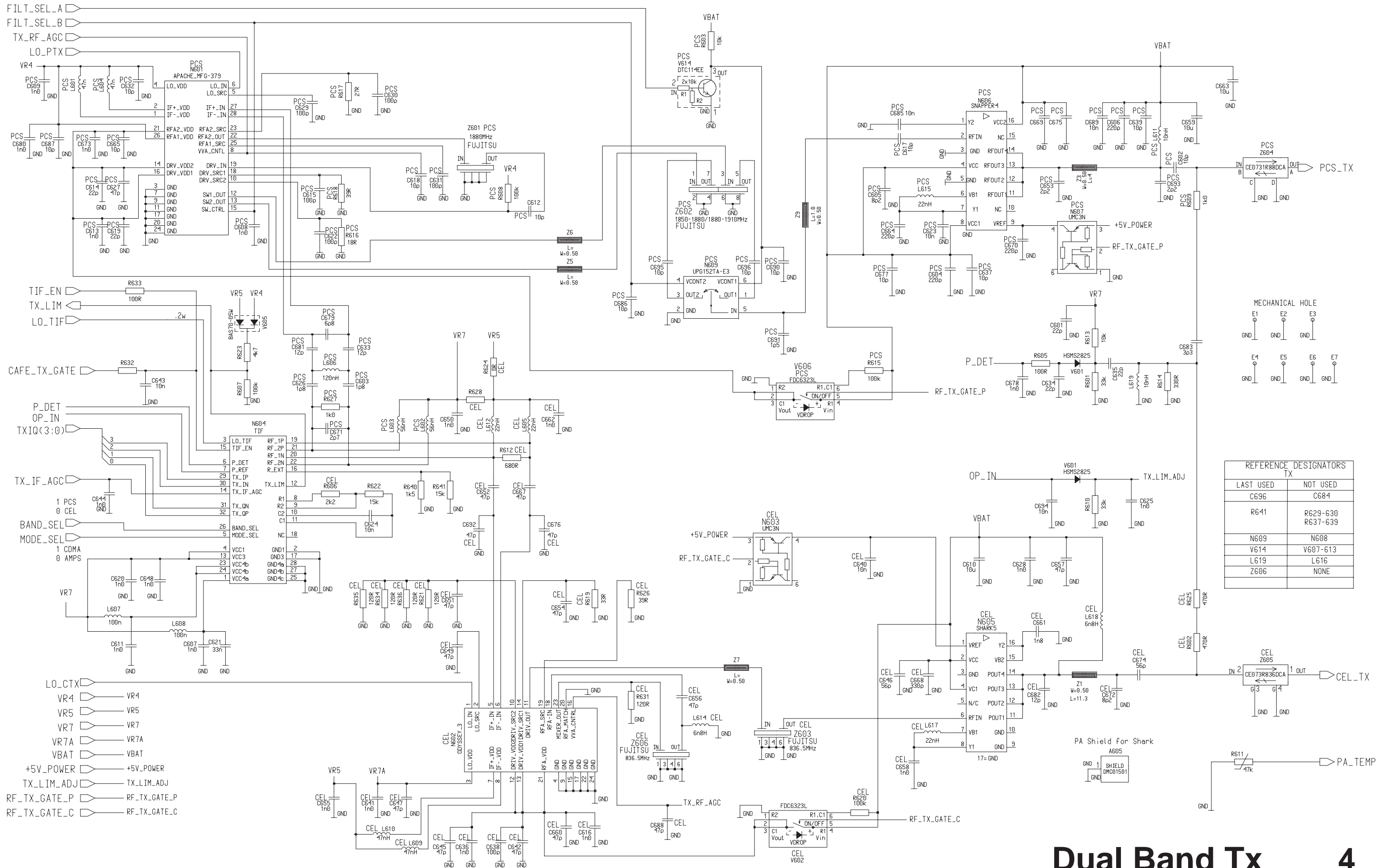

REFERENCE DESIGNATORS TX	
LAST USED	NOT USED
C696	C684
R641	R629-630 R637-639
N609	N608
V614	V607-613
L619	L616
Z606	NONE

Dual Band Tx 4

Circuit Diagram of Synthesizer (Version 06.0 Edition 5) for layout version 24

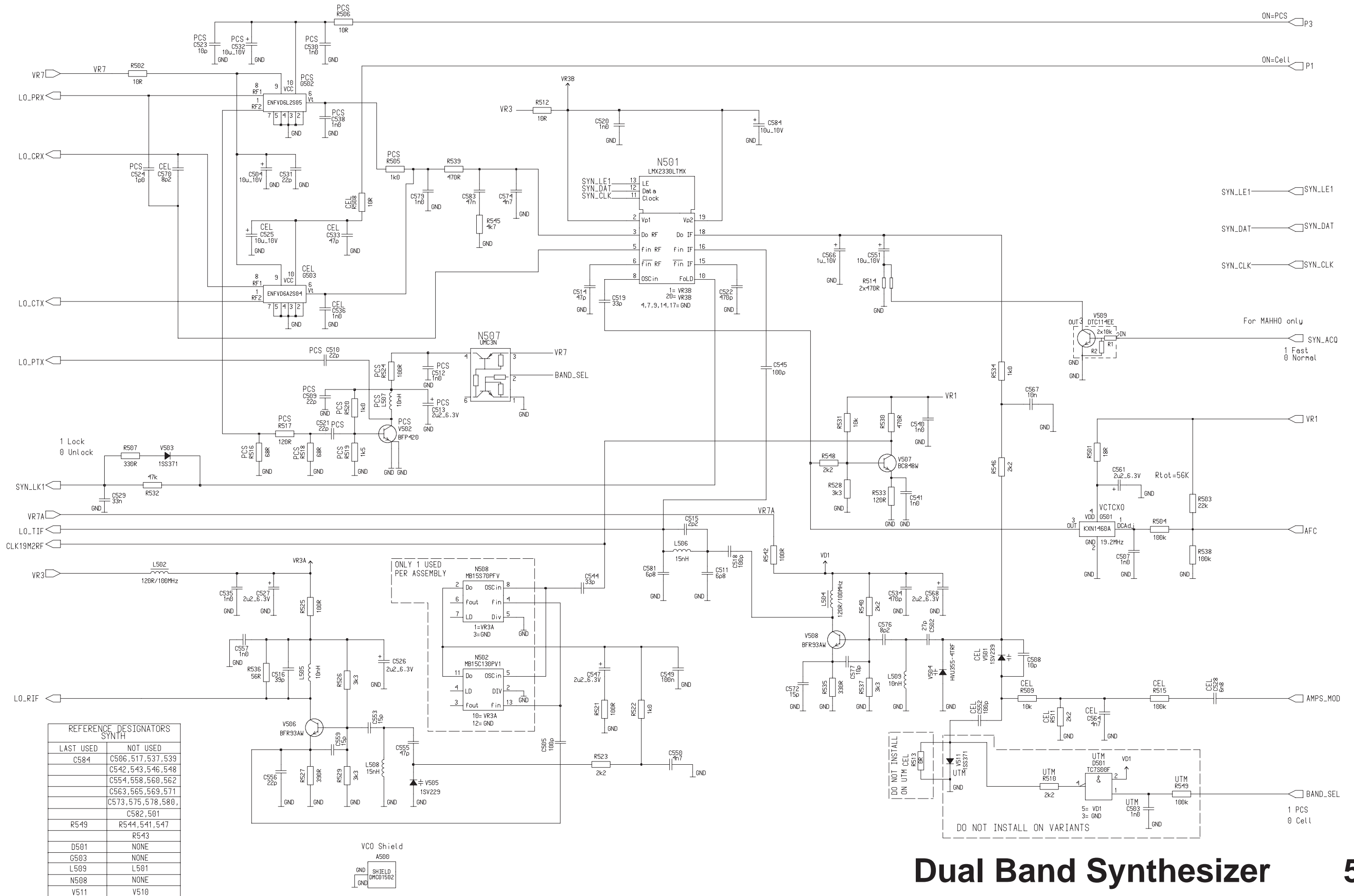

REFERENCE DESIGNATORS SYNTH	
LAST USED	NOT USED
C584	C506, 517, 537, 539
	C542, 543, 546, 548
	C554, 558, 560, 562
	C563, 565, 569, 571
	C573, 575, 578, 580,
	C582, 501
R549	R544, 541, 547
	R543
D501	NONE
G503	NONE
L509	L501
N508	NONE
V511	V510

Dual Band Synthesizer

Circuit Diagram of Cafe (Version 06.0 Edition 8) for layout version 24

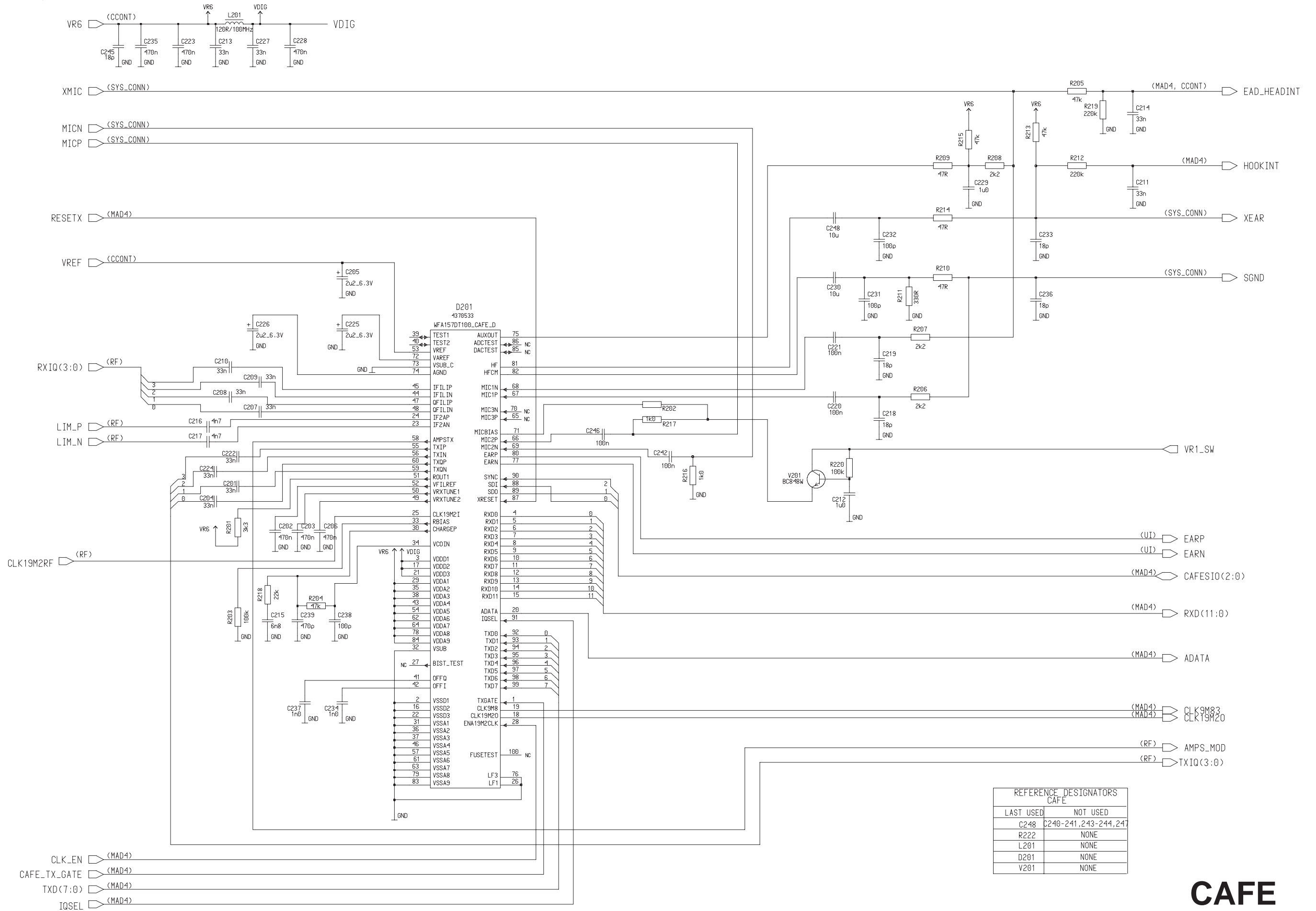

CAFE

Circuit Diagram of MAD4 (Version 06.0 Edition 8) for layout version 24

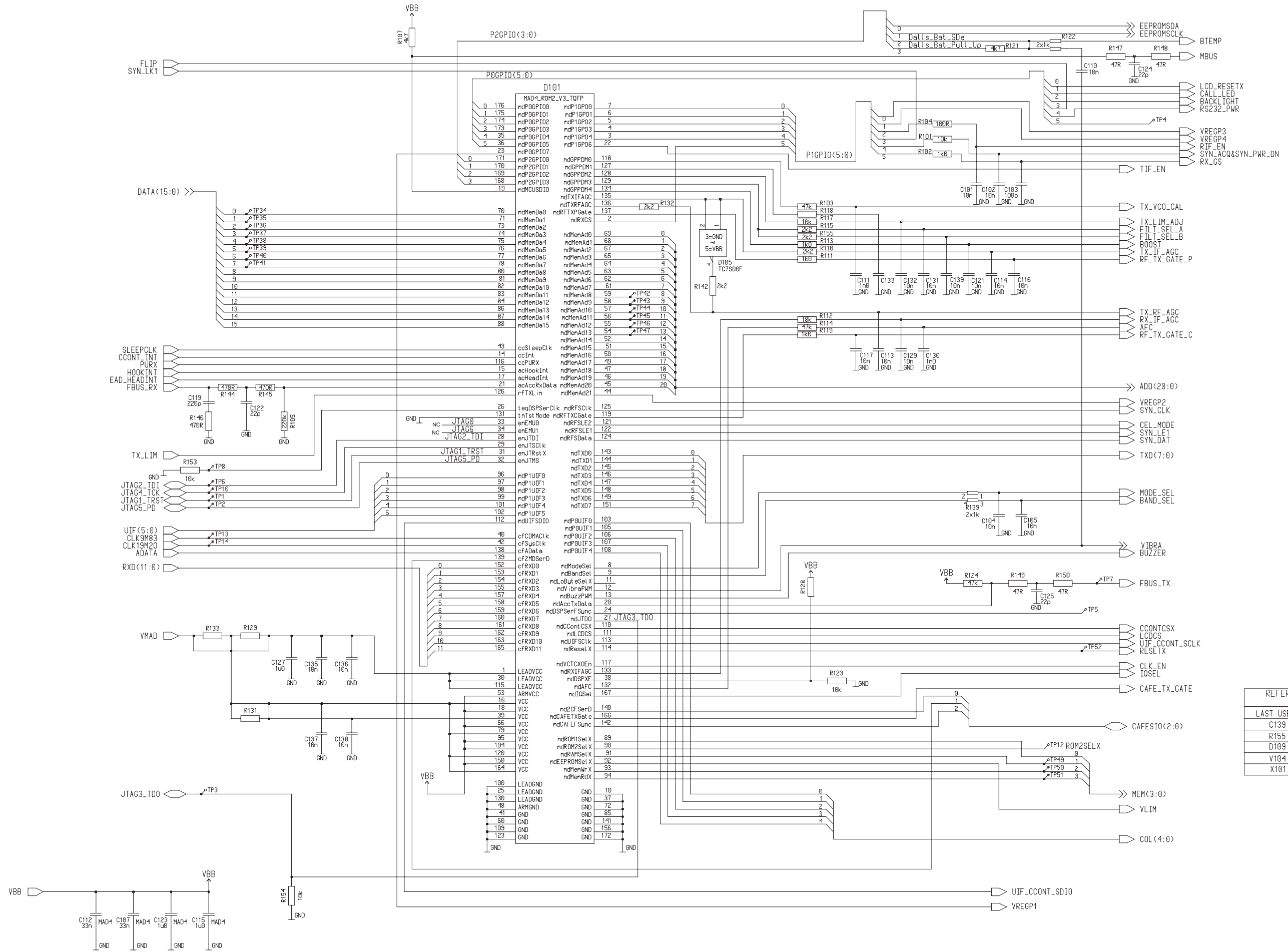

REFERENCE DESIGNATORS MAD	
LAST USED	NOT USED
C139	NONE
R155	R135,140,152
D109	D106,108
V104	V102
X101	NONE

Circuit Diagram of MAD4 External Memories (Version 06.0 Edition 4) for layout version 24

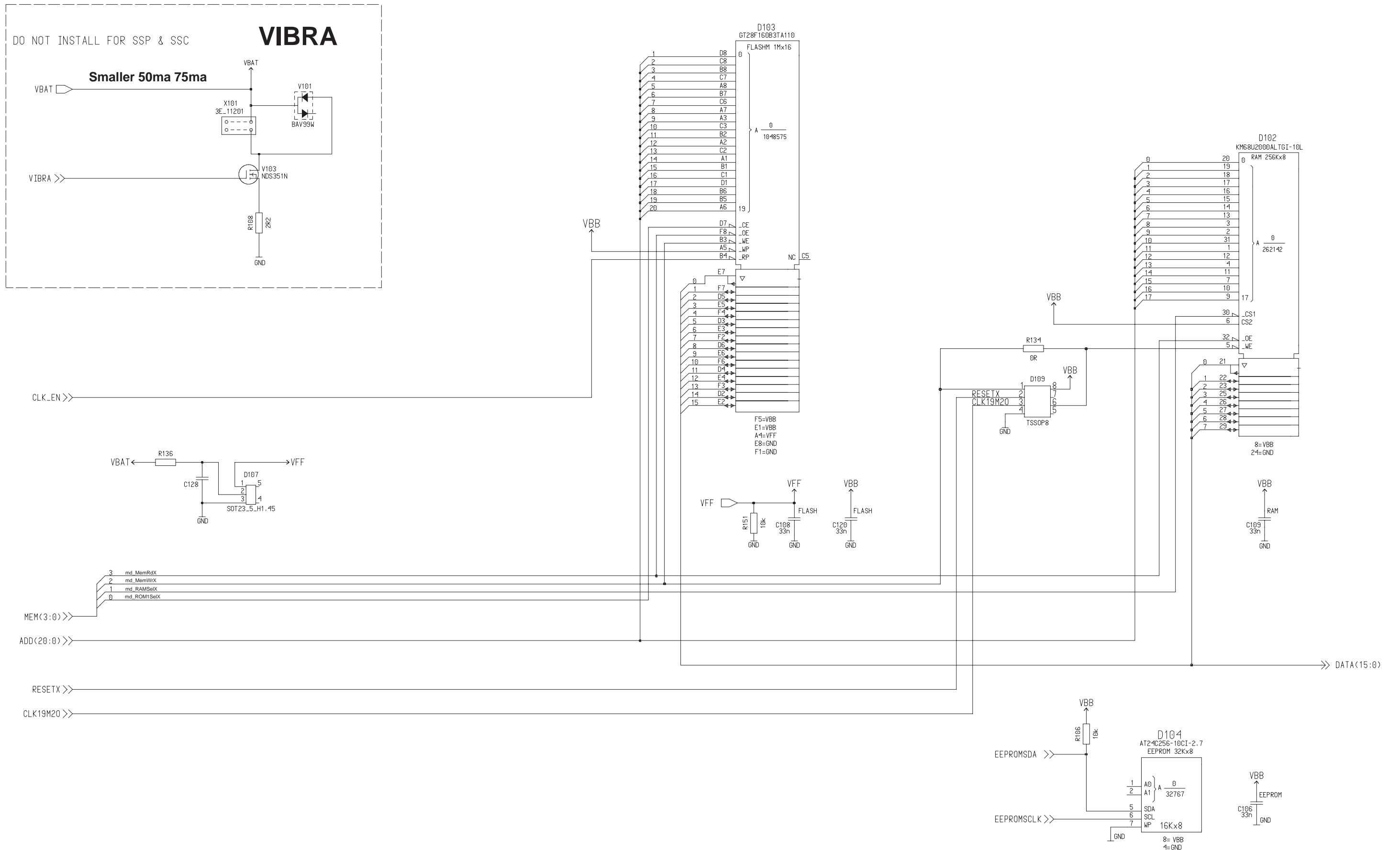

Layout Diagram of UF41 – Top (issue 5.0, Version 24)

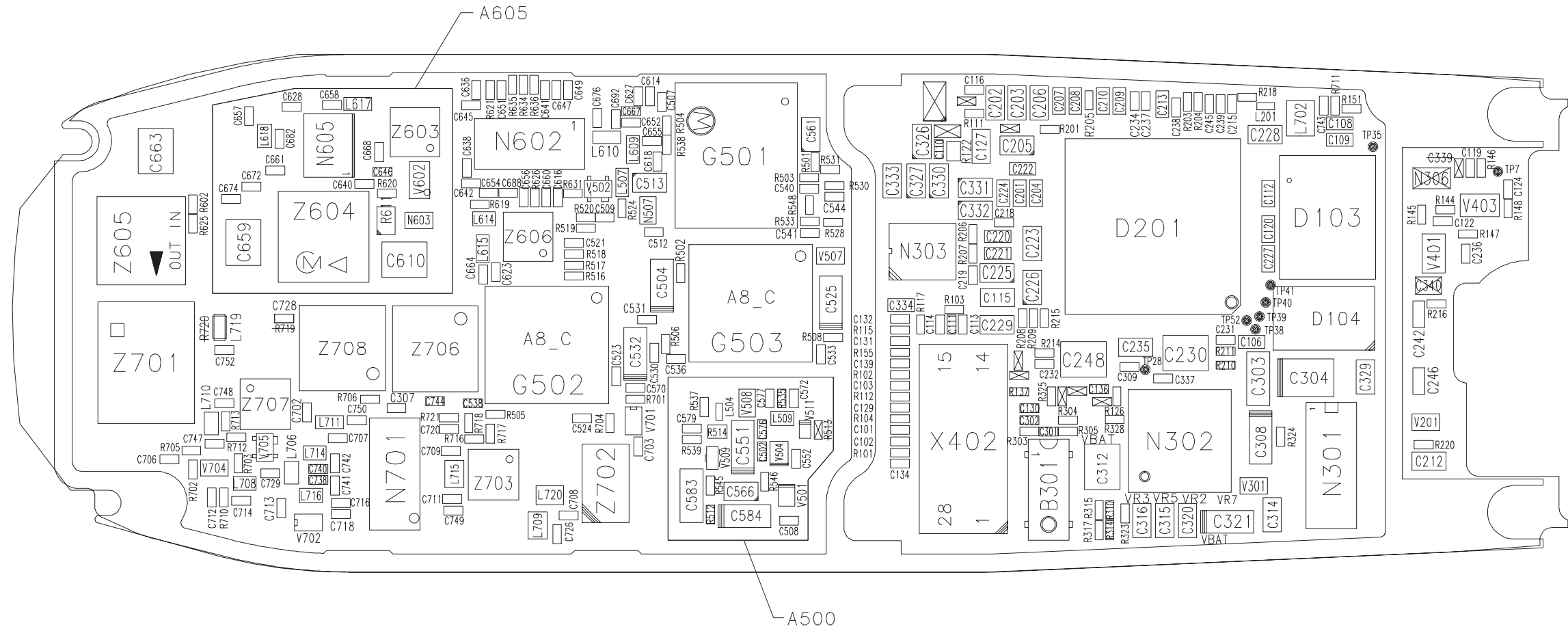

Layout Diagram of UF41 – Bottom (issue 5.0, Version 24)

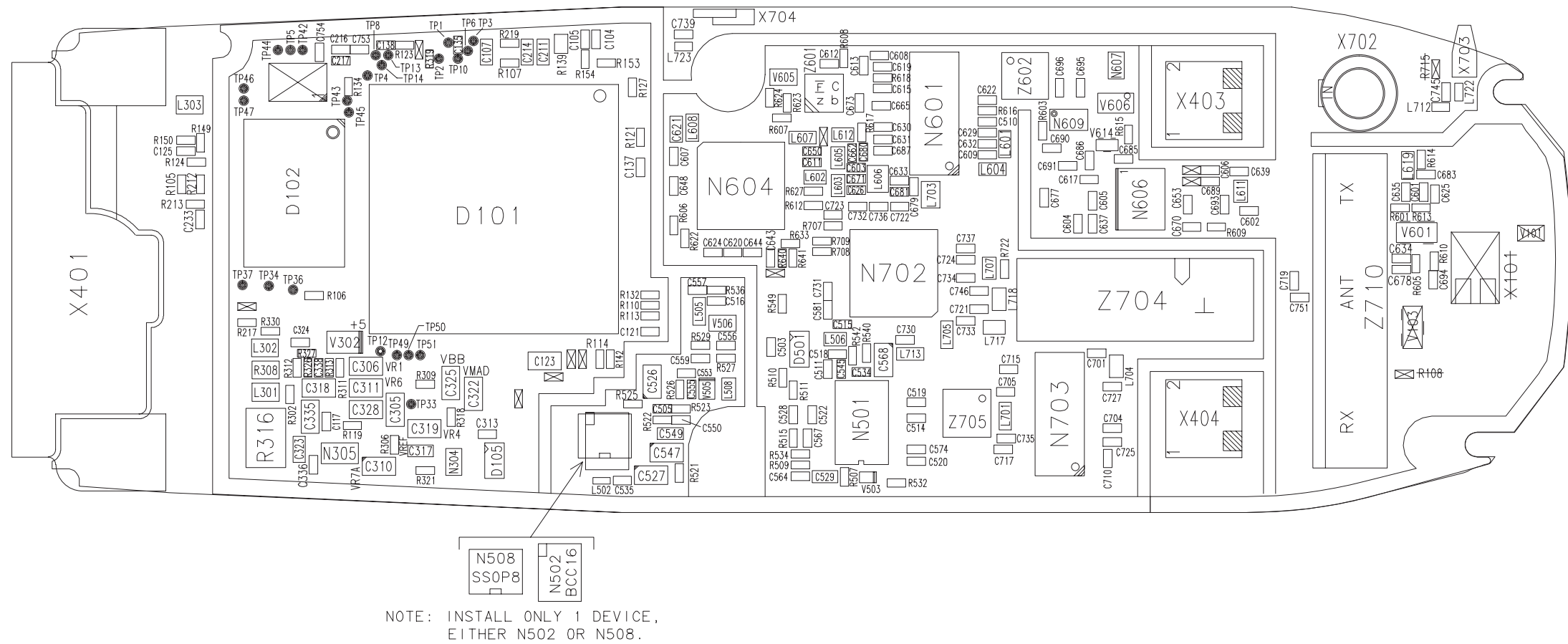

NOTE: INSTALL ONLY 1 DEVICE,
EITHER N502 OR N508.

